

# 3553R 空心杯有刷电机

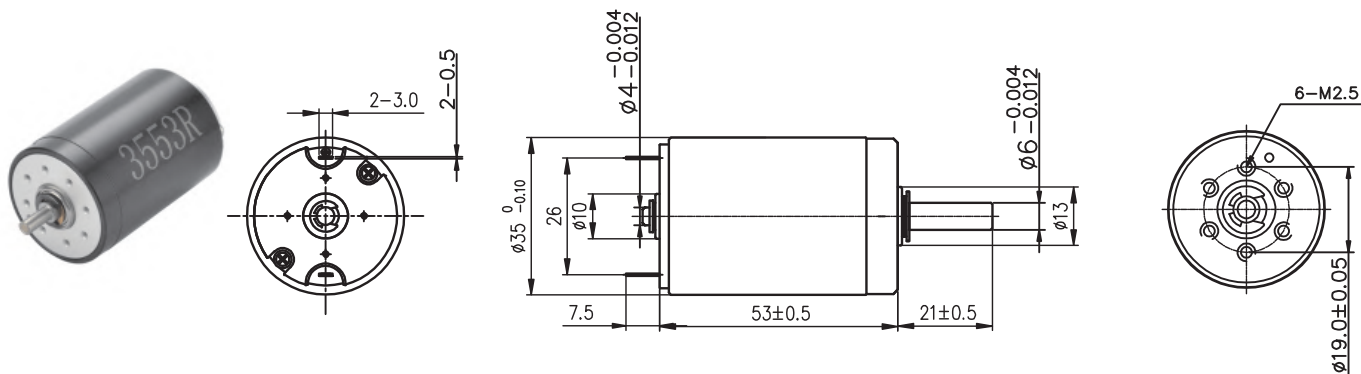

典型应用 Typical Applications: 舵机、智能小机器人

电机参数 ( Motor data )		01A	02A	03A	04A
额定电压下数值 (Values at nominal voltage)					
1 额定电压 (Nominal voltage)	V	24	12	24	32
2 空载转速 (No load speed)	rpm	6500	4800	4800	4700
3 空载电流 (No load current)	mA	80	90	60	60
4 额定转速 (Nominal speed)	rpm	5980	4200	4128	4089
5 额定转矩 (最大连续转矩) (Nominal torque)	mNm	20	15	15	15
6 额定电流 (最大连续电流) (Nominal current)	A	0.66	0.70	0.37	0.28
7 堵转转矩 (Stall torque)	mNm	255	117	107	113
8 堵转电流 (Stall current)	A	7.38	5.00	2.29	1.78
9 最大效率 (Max efficiency)	%	82	77	74	71
电机常数 (Motor constant)					
10 相间电阻 (Terminal resistance)	Ω	3.25	2.40	10.5	18
11 转矩常数 (Torque constant)	mNm/A	34.57	23.41	46.8	63.7
12 速度常数 (Speed constant)	rpm / V	271	400	200	147

## 其它特性参数 Other characteristic parameters 01A电机曲线图

- 13 环境温度范围 (Ambient temperature) -10 - 40°C
- 14 绕组最高允许温度 (Max permissible winding temperature) 80°C
- 15 最高允许转速 (Max permissible speed) 10000rpm
- 16 电极磁极对数 (Number of the pole pairs) 1
- 17 换向器片数 (Number of the commutator segments) 5
- 18 电机质量 (Weight) 305g

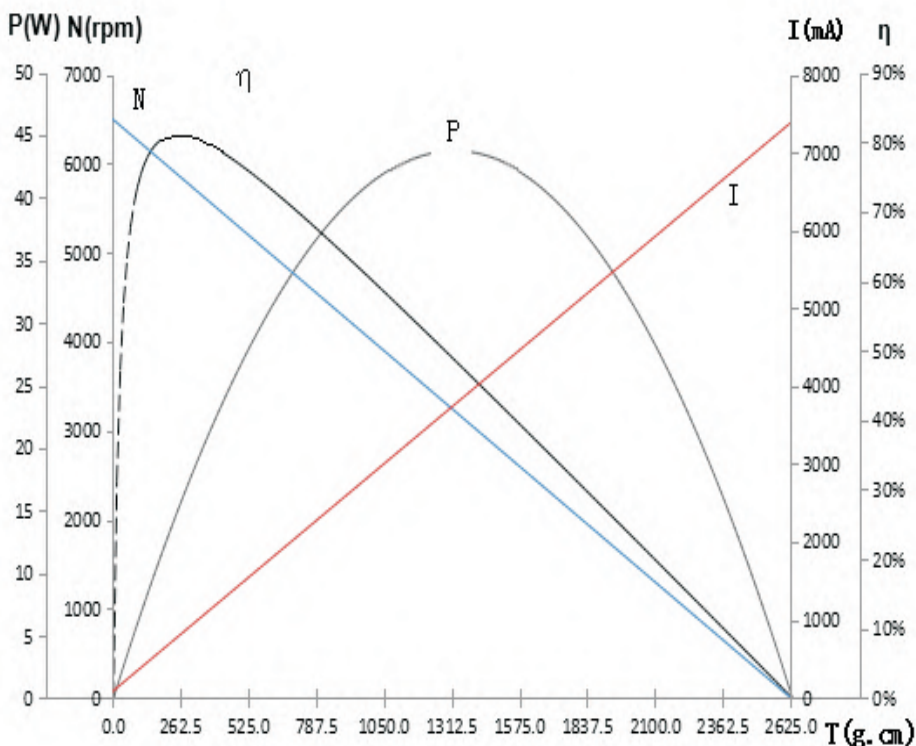

YTK CO.,LTD.  
 info@ytk-group.co.jp  
 Http://www.ytk-group.co.jp