

# 1515R 空心杯有刷电机

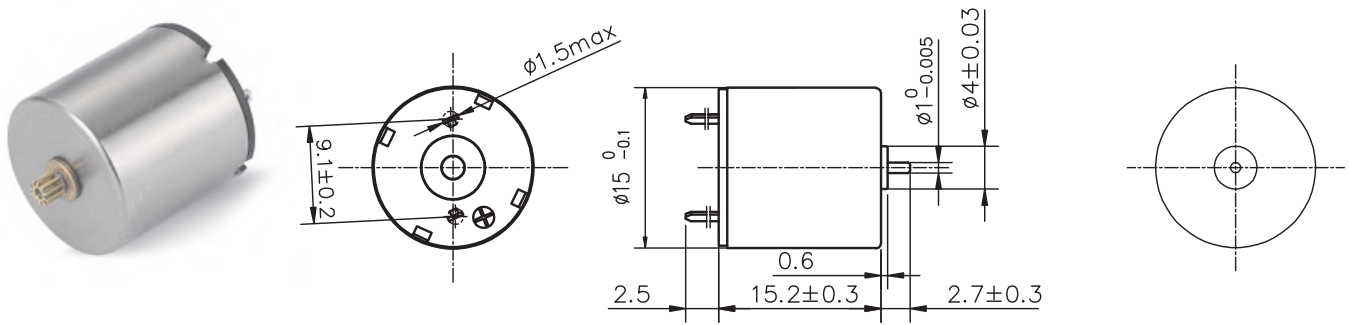

典型应用 Typical Applications: 舵机、智能小机器人

电机参数 ( Motor data )		05AL1	04A	03A	12A	05A
额定电压下数值 (Values at nominal voltage)						
1 额定电压 ( Nominal voltage )	v	3.3	4.5	5	5	5
2 空载转速 (No load speed)	rpm	13100	22500	17500	25500	21000
3 空载电流 (No load current)	mA	40	50	45	96	45
4 额定转速 (Nominal speed)	rpm	11397	20137	15225	23205	18375
5 额定转矩 (最大连续转矩) (Nominal torque)	mNm	0.50	0.50	0.70	0.50	0.70
6 额定电流 (最大连续电流) (Nominal current)	A	0.24	0.31	0.30	0.36	0.36
7 堵转转矩 (Stall torque)	mNm	3.79	4.84	5.34	5.56	5.57
8 堵转电流 (Stall current)	A	1.61	2.59	2.00	3.03	2.50
9 最大效率 (Max efficiency)	%	74	77	74	72	76
电机常数 (Motor constant)						
10 相间电阻 (Terminal resistance)	Ω	2.05	1.74	2.50	1.65	2.00
11 转矩常数 (Torque constant)	mNm/A	2.36	1.87	2.68	1.84	2.23
12 速度常数 (Speed constant)	rpm / V	3970	5000	3500	5100	4200

## 其它特性参数 Other characteristic parameters 05AL1电机曲线图

- 13 环境温度范围 (Ambient temperature) -10 - 40°C
- 14 绕组最高允许温度 (Max permissible winding temperature) 80°C
- 15 最高允许转速 (Max permissible speed) 30000rpm
- 16 电极磁极对数 (Number of the pole pairs) 1
- 17 换向器片数 (Number of the commutator segments) 5
- 18 电机质量 (Weight) 20.9g

