

# 1215R 空心杯有刷电机

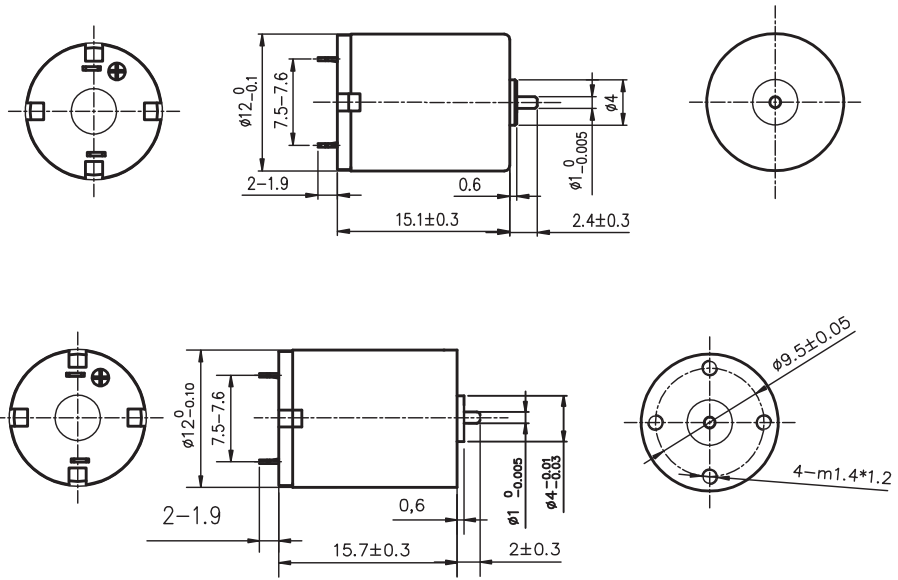

Coreless Motors

典型应用 Typical Applications: 舵机、智能小机器人

电机参数 ( Motor data )	01A	06A	21A	18A	54A
额定电压下数值 (Values at nominal voltage)					
1 额定电压 (Nominal voltage) v	4.5	4.5	7.4	7.4	12
2 空载转速 (No load speed) rpm	18360	21000	28000	21000	31000
3 空载电流 (No load current) mA	60	60	60	30	40
4 额定转速 (Nominal speed) rpm	15422	17745	23800	18585	27900
5 额定转矩 (最大连续转矩) (Nominal torque) mNm	0.59	0.59	0.78	0.50	1.00
6 额定电流 (最大连续电流) (Nominal current) A	0.37	0.34	0.36	0.17	0.31
7 堵转转矩 (Stall torque) mNm	3.68	3.80	5.23	4.35	10.11
8 堵转电流 (Stall current) A	1.61	1.88	2.11	1.32	2.79
9 最大效率 (Max efficiency) %	70	71	73	75	79
电机常数 (Motor constant)					
10 相间电阻 (Terminal resistance) Ω	2.80	2.40	3.50	5.60	4.30
11 转矩常数 (Torque constant) mNm/A	2.29	2.00	2.47	3.30	3.62
12 速度常数 (Speed constant) rpm / V	4080	4667	3784	2838	2583

## 其它特性参数 Other characteristic parameters 01A电机曲线图

- 13 环境温度范围 (Ambient temperature) -10 - 40°C
- 14 绕组最高允许温度 (Max permissible winding temperature) 80°C
- 15 最高允许转速 (Max permissible speed) 35000rpm
- 16 电极磁极对数 (Number of the pole pairs) 1
- 17 换向器片数 (Number of the commutator segments) 5
- 18 电机质量 (Weight) 6.5g

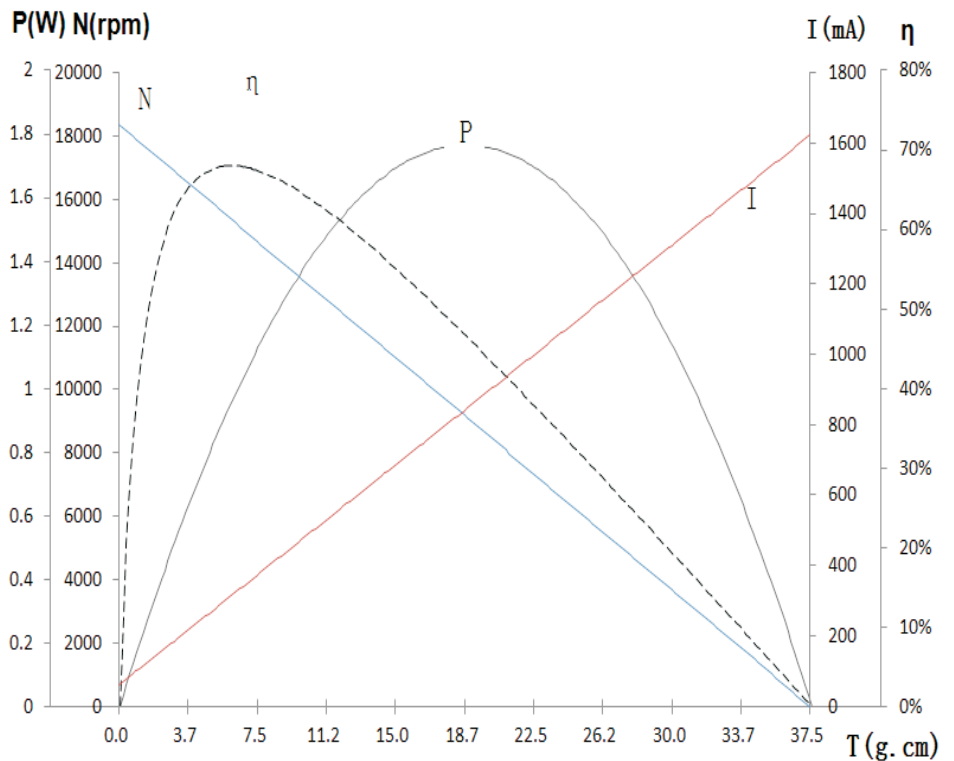

YTK CO.,LTD.  
 info@ytk-group.co.jp  
 Http://www.ytk-group.co.jp