

**EZ**kontrol



# EZkontrol Series

Permanent Magnet Synchronous Motor Controller

## User's Manual

## The Product

The EZkontrol series permanent magnet synchronous motor (PMSM) controllers are built with ARM 32-bit Cortex-M4 core processor and features the latest Field Oriented Control (FOC) vector control technology, enabling real time control of motor torque, field excitation, speed and power efficiently. Choice of voltage ranges between 24V to 240V and power from 1KW up to 30KW. Switch between Sinewave or Squarewave by downloading their respective firmwares over-the-air.

## The Company

For over a decade, Goldenmotor has roots deeply embedded in the field of new age electric propulsion, developing and crafting a new generation of electric motors and controllers for the ever-evolving EV market. Every nook and cranny of our product design reflects years of accumulated experience in applications used in the electric vehicles, boats and various machines, understanding what the customer needs and delivering our core technologies affordably with an extra touch of elegance. As your needs evolve, we evolve with you.

## The Features

The EZkontrol series of BLDC motor FOC controllers are our latest addition to your arsenal. With up to 30kWs of power in a variety of voltages and amperage (up to 240V(DC) or 2000Amps) in our flagship E series, there is undoubtedly a model that suits your requirements. Expect the EZkontrol to drive your (or our) BLDC motors smoothly and efficiently after a brief EZ & intuitive installation.

## The Fast and The Wireless

Armed with powerful ARM 32-bit Cortex-M4 core processors, it will chew through vector control algorithms at lightning speed, delivering Real-Time torque, excitation, speed and power control as well as zero-delay monitoring functions via Bluetooth.

## The Setup

Gone are the days of a dedicated programming device, old USB cables and confusing interfaces. The EZkontrol's simple and intuitive automatic self-learning calibration of motor parameters allows you to get your motors up and running in no time...  
 ... on your Mobile Phone!  
 ... via built-in Bluetooth!  
 ... on a floating App!  
 ... obtained via QR code!

Hundreds of programmable control parameters for you to tweak and fine tune your drive system to perfection! Get firmware updates online the same EZ way! It doesn't get any EZ-ier than this! It fully supports OTA (Over the Air) firmware upgrades via smart phones. You can even switch between Sinewave control or Squarewave control in the same EZ controller by downloading the respective firmware OTA.

## All Aboard the CAN BUS

Want even more Kustomized Kontrol? EZkontrol supports multiple communication protocols and interfaces such as CAN-BUS, RS485, UART etc. Sample source codes are available to jump start your CAN-BUS application development, find out more in our CAN protocol manuals.

## Chill Out

Every EZkontrol features an aluminum base heat sink that is Liquid-Cooling Ready with 4 pre-drilled inlets/outlets which are compatible with standard water tap threads fittings. Choose from any 2 of these 4 holes to circulate your choice of cooling fluid via an external cooling pump.

## Decadent Display

Free Speedometer instruments Android and iOS apps for you with fancy looking User Interfaces. Connect your smartphone to EZkontrol via the built-in bluetooth component. The app creates a very useful log file to record your motor and controller status, running data (datetime, voltage, current, rpm, motor temperature etc.) with date-time stamp at each time interval (user definable in seconds).

# WeChat Host Softwares

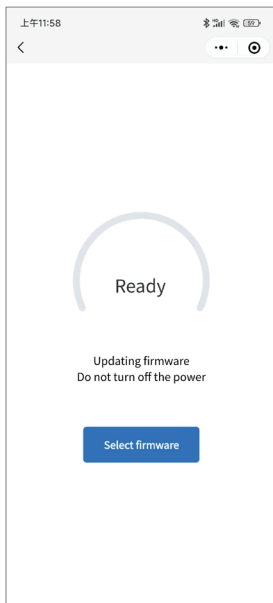
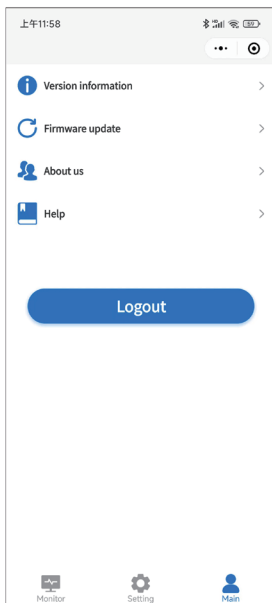
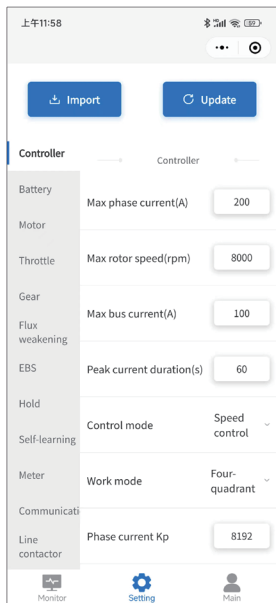
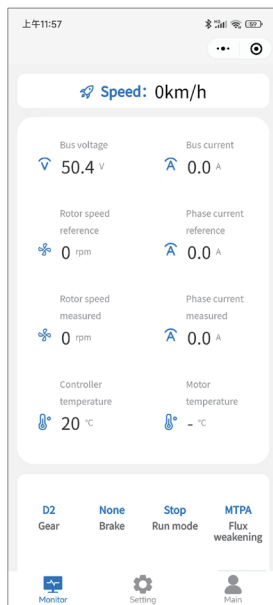
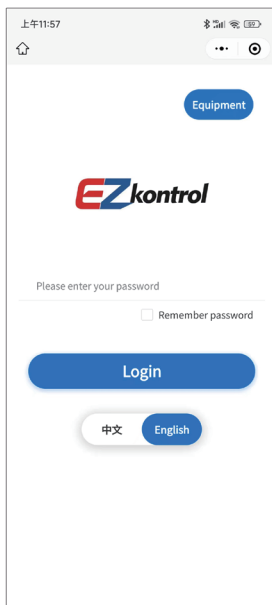

## Models

Rated Voltage (V)	Item No.	Max. Voltage (V)	Max. Phase Current (A)	Rated Phase Current (A)	Max. Bus Current (A)	Motor Rated Power (KW)
48	EZkontrol A48400	75	400	160	200	2-4
	EZkontrol A48500		500	200	250	3-5
	EZkontrol B48800		800	320	400	5-8
	EZkontrol B481000		1000	400	500	6-10
	EZkontrol C481200		1200	480	600	7-12
	EZkontrol C481500		1500	600	750	9-14
	EZkontrol D481600		1600	640	800	9-15
	EZkontrol E482000		2000	800	1000	12-19
EZkontrol E482500	2500	1000	1250	14-24		
72	EZkontrol A72400	95	400	160	200	3-6
	EZkontrol A72500		500	200	250	4-7
	EZkontrol B72800		800	320	400	7-12
	EZkontrol B721000		1000	400	500	9-14
	EZkontrol C721200		1200	480	600	10-17
	EZkontrol C721500		1500	600	750	13-22
	EZkontrol D722000		2000	800	1000	17-29
	EZkontrol E722500		2500	1000	1250	22-36
96	EZkontrol A96300	120-130	300	120	150	3-6
	EZkontrol A96400		400	160	200	5-8
	EZkontrol B96600		600	240	300	7-12
	EZkontrol B96800		800	320	400	9-15
	EZkontrol C96900		900	360	450	10-17
	EZkontrol C961200		1200	480	600	14-23
	EZkontrol E961500		1500	600	750	17-29
	EZkontrol E962000		2000	800	1000	23-38
120	EZkontrol A120300	145	300	120	150	4-7
	EZkontrol B120600		600	240	300	9-14
	EZkontrol C120900		900	360	450	13-22
	EZkontrol D1201200		1200	480	600	17-29
	EZkontrol E1201500		1500	600	750	22-36

144	EZkontrol A144200	190	200	80	100	3-6
	EZkontrol B144400		400	160	200	7-12
	EZkontrol C144600		600	240	300	10-17
	EZkontrol D144800		800	320	400	14-23
	EZkontrol E1441000		1000	400	500	17-29
240	EZkontrol A240100	290	100	40	50	3-5
	EZkontrol B240200		200	80	100	6-10
	EZkontrol C240300		300	120	150	9-14
	EZkontrol D240400		400	160	200	12-19
	EZkontrol E240500		500	200	250	14-24

# Wiring Diagram with DC Contactor

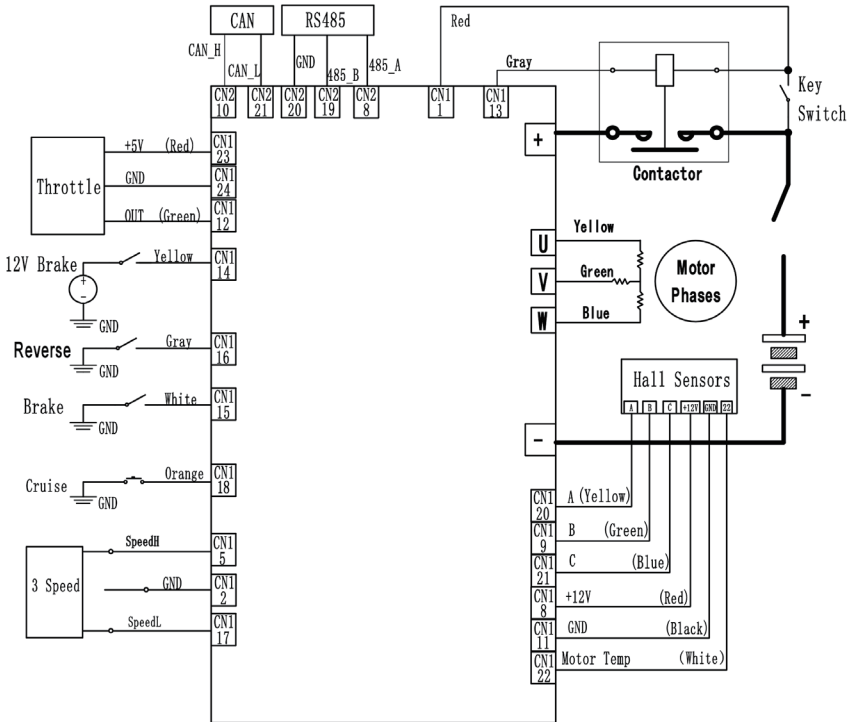

CN1

1	2	3	4	5	6	7	8	9	10	11	12
13	14	15	16	17	18	19	20	21	22	23	24

CN2

1	2	3	4	5	6	7	8	9	10	11
12	13	14	15	16	17	18	19	20	21	22

# Wiring Diagram without DC Contactor

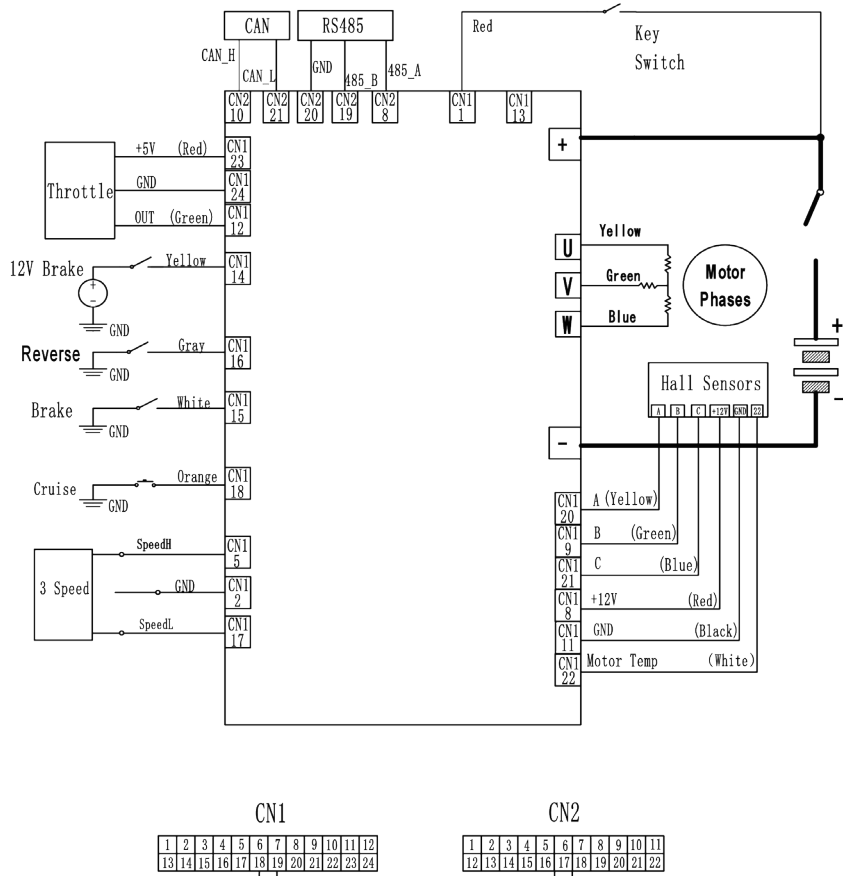

## Interface Definition

Pin No.	Wiring Color	Function Definition	Function Description
CN1-1	Red	KI	Key Switch
CN1-13	Grey	LCON	DC Contactor Coil
CN1-2	Black	GND	Ground
CN1-14	Yellow	BrakeH+	High Brake +
CN1-3	Black	BrakeH-	High Brake -
CN1-15	White	BrakeL	Low Brake
CN1-4	Green	FWD	Forward
CN1-16	Grey	REV	Reverse
CN1-5	Blue	peedH	High Speed
CN1-17	Brown	peedL	Low Speed
CN1-18	Orange	Cruise	Cruise
CN1-8	Red	+12V	Motor main position sensor power +12V
CN1-20	Yellow	HA_A_M	Motor main position sensor signal, Hall HA or encoder A
CN1-9	Green	HB_B_M	Motor main position sensor signal, Hall HB or encoder B
CN1-21	Blue	HC_Z_M	Motor main position sensor signal, Hall HC or encoder Z
CN1-22	White	TEMP_M	Motor Temperature Sensor
CN1-11	Black	GND	Motor position sensor power GND
CN1-23	Red	+5V	Main Throttle Power +5V
CN1-12	Green	ThrottleM	Main Throttle Signal
CN1-24	Black	GND	Main Throttle Power GND
CN2-5	Black	PDO-	Speed Pulse power supply -
CN2-16	Purple	IF	All-in-one Connection/Speed Pulse signal output
CN2-8	White	R485_A	R485 A
CN2-19	Purple	R485_B	R485 B
CN2-9	Brown	R485_TERM	R485 120Ω matching resistance
CN2-20	Black	GND	GND
CN2-10	Yellow	CAN_H	CAN H
CN2-21	Green	CAN_L	CAN L
CN2-11	Brown	CAN_TERM	CAN 120Ω matching resistance
CN2-22	Black	CAN_GND	CAN GND



## System Protection Characteristics

LED Blinking Times	Error	Error Description	Solution
1	Overcurrent	The current of phase wires are abnormal.	Check if the phase wires are damaged or there is any short circuit.
2	Overload	The load exceeds the controller's capacity.	Change a controller with bigger power.
3	Overvoltage	The bus voltage exceeds the controller's default value.	Check if the bus voltage matches the controller's default value, or check the controller's default value.
4	Undervoltage	The bus voltage is lower than the controller's default value.	Check the bus voltage and the battery capacity, or check the controller's default value.
5	Controller Overtemperature	The temperature of the controller is higher than 70 °C .	Improve the controller's heat dissipation, or lower the controller's value of Max. phase current, or change a controller with bigger power.
6	Motor Overtemperature	The temperature of the motor exceeds its default value.	Improve the motor's heat dissipation, or lower the controller's value of Max. phase current, or change a motor with bigger power.
7	Motor Stall/Block	Motor stall/Block time exceeds default value.	Check if there is stall/block condition on motor shaft.
8	Motor Phase Wire Disconnection	The phase wires are not connected correctly or disconnected.	Check the wire connections of the motor and controller.
9	Motor Main Sensor	The throttle output signal is valid when powered on.	Check if the motor's main sensor is good.
10	Motor Auxiliary Sensor	Motor Auxiliary Sensor Error	Check if the motor's auxiliary sensor is good.
11	Encoder Alignment	Encoder Alignment Error	Check if the motor's encoder alignment signal is good.
12	Throttle Protection	The throttle output signal is valid when powered on.	Check the throttle or the min. value of its error parameters.
13	Main Throttle	The output voltage of main throttle is abnormal.	Check the main throttle or the max. and min. values of its error parameters.
14	Auxiliary Throttle	The output voltage of auxiliary throttle is abnormal.	Check the auxiliary throttle or the max. and min. values of its error parameters.
15	Precharge	Precharge Error	Return to factory service.
16	DC Contactor	DC Contactor Error	Check if the DC Contactor is good or the contact is good.
17	MOSFET	The controller's MOS detection is abnormal.	Return to factory service.
18	Current Sensor	The controller's current sensor detection is abnormal.	Return to factory service.
19	Self-learning	Self-learning Failure	Check the self-learning parameter settings and if the self-learning method is correct.
20	RS485	RS485 Communication Error	Only the RS485 control mode is valid, check if the RS485 communication wire or VCU is normal.
21	CAN	CAN Communication Error	Only the CAN control mode is valid, check if the CAN communication wire or VCU is normal.
22	Softwares	System Softwares Error	Return to factory service.

# Dimensions

## A Series Dimensions

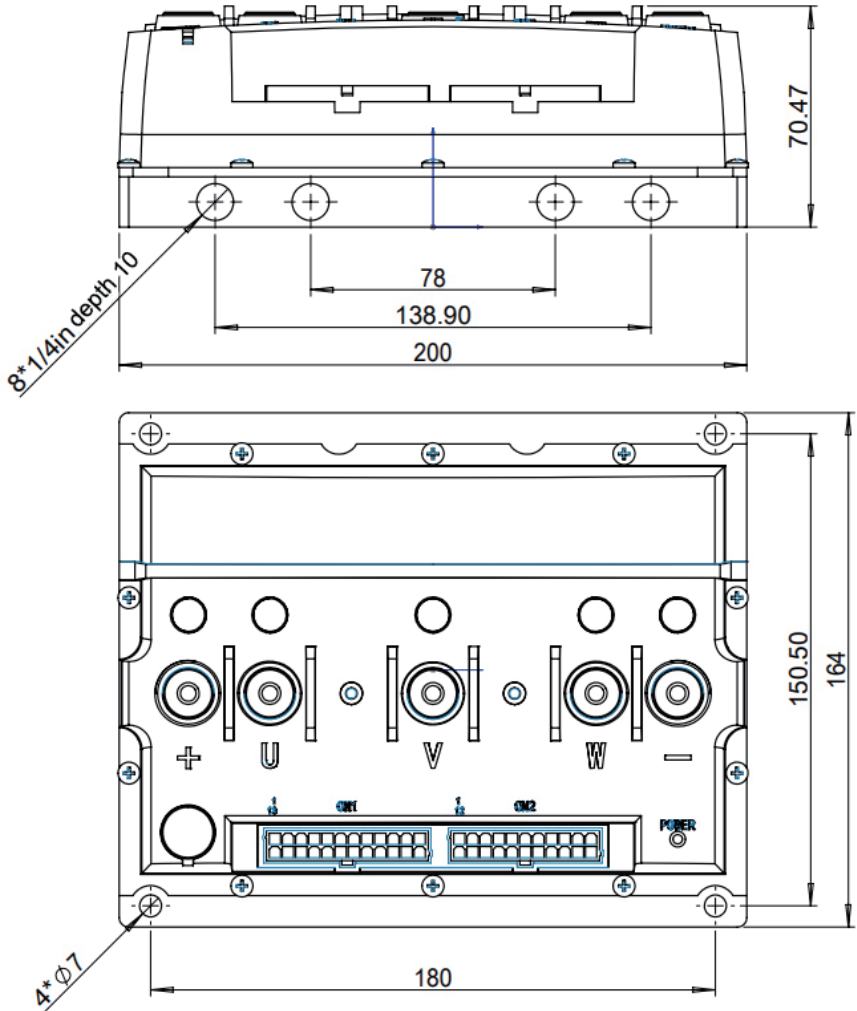

## B Series Dimensions

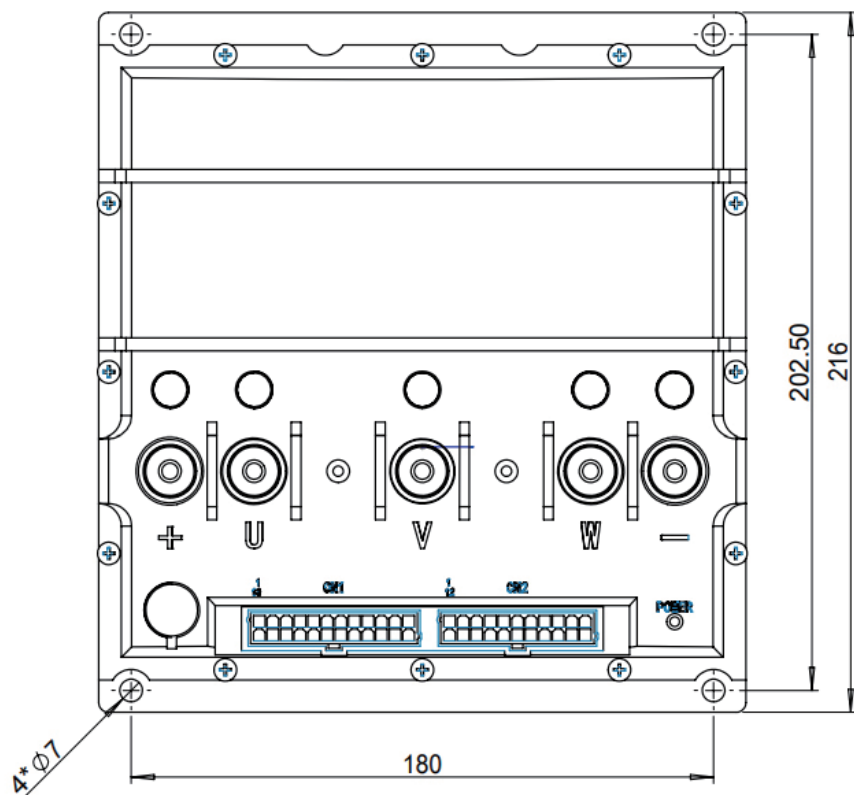

## C Series Dimensions

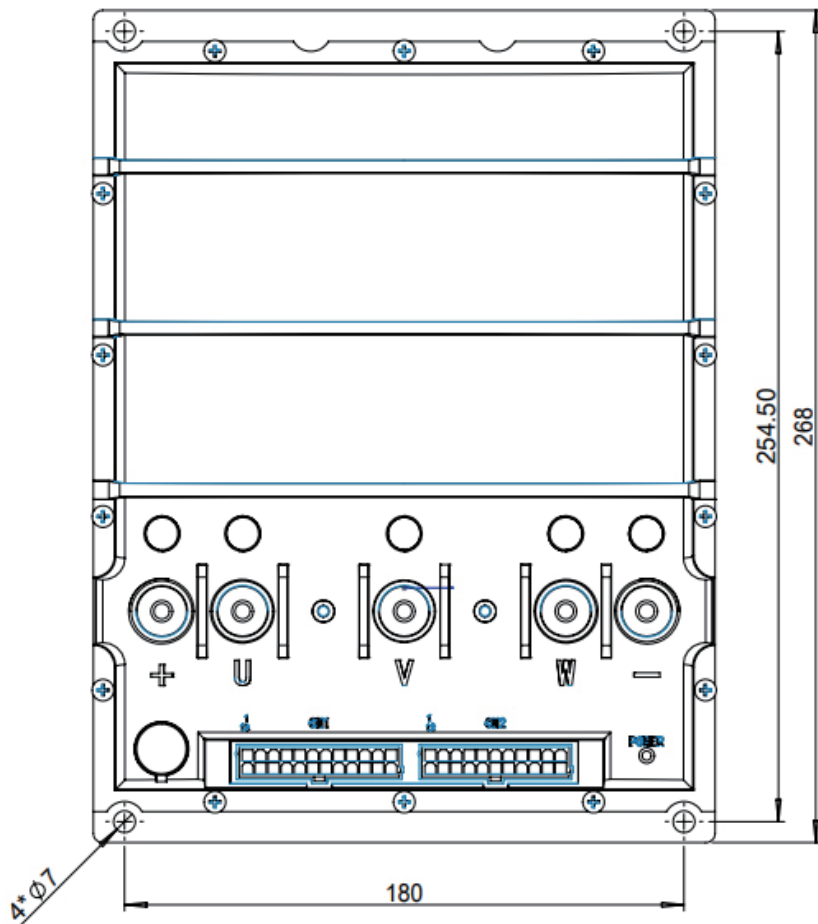

## D Series Dimensions

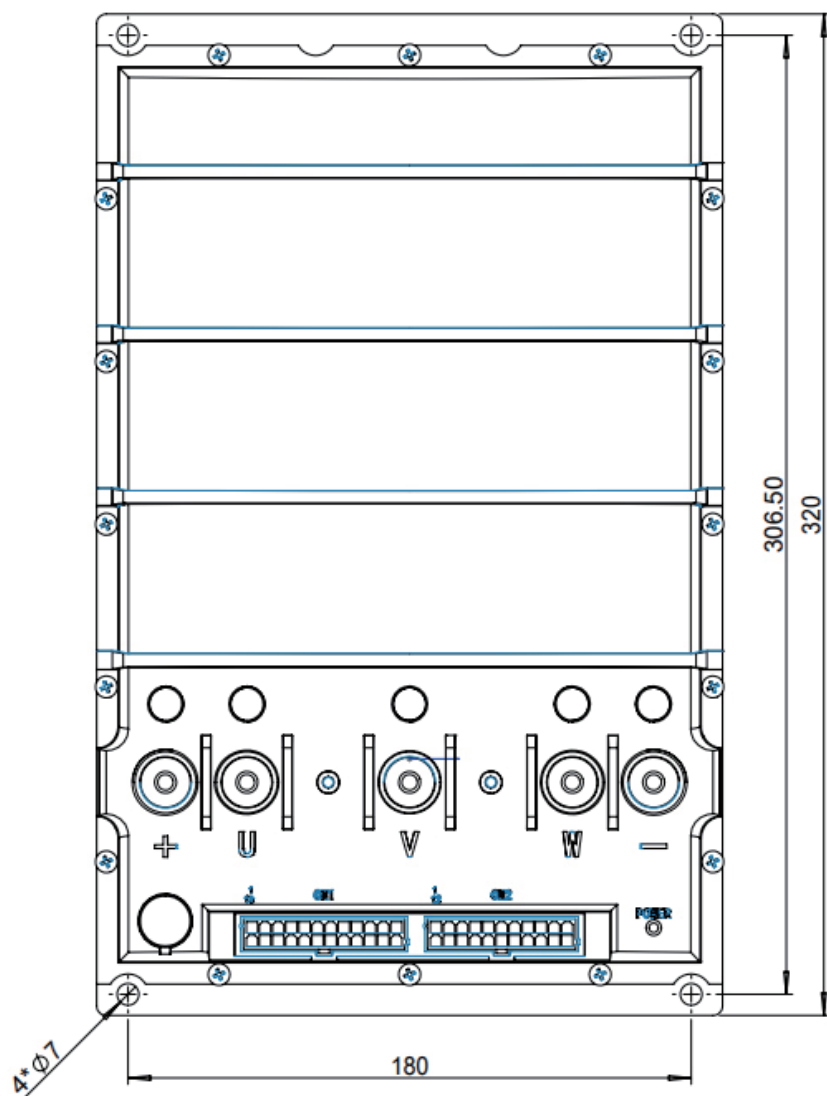

## E Series Dimensions

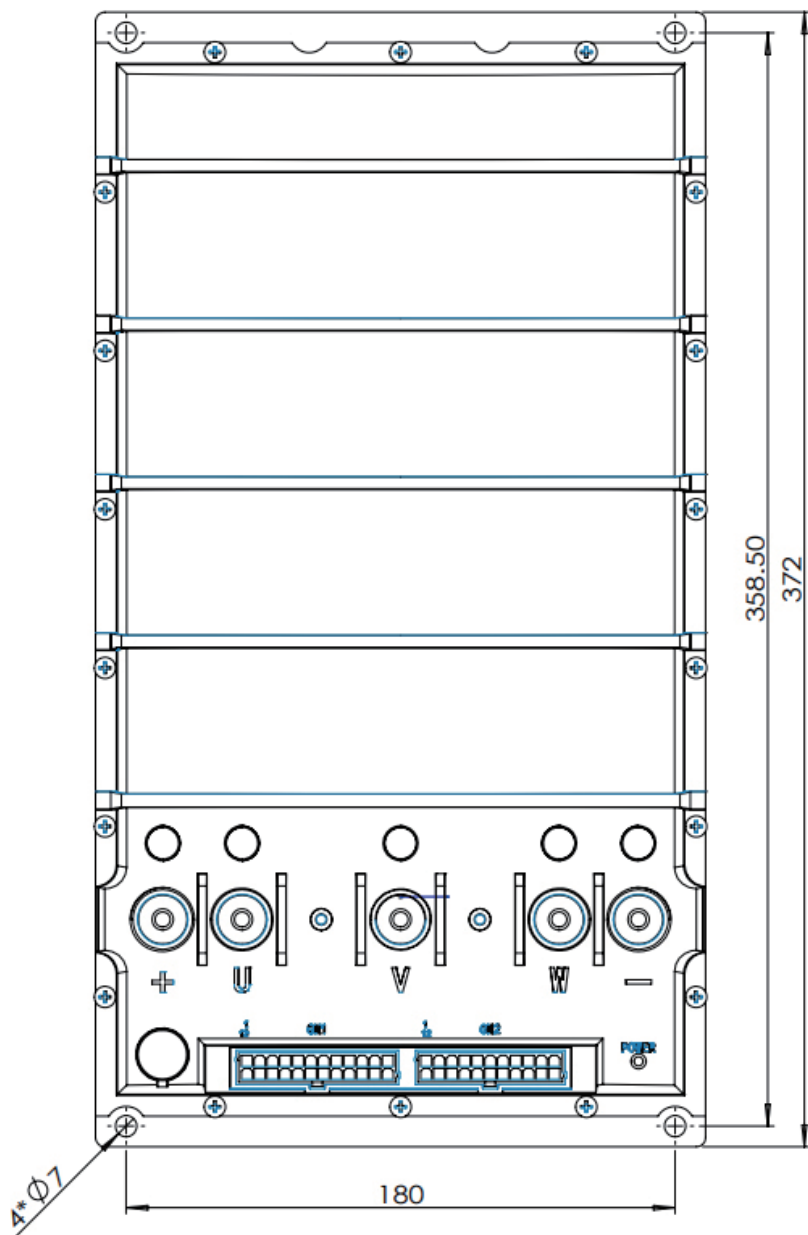



*kontrol everything*

YTK CO.,LTD.  
[Http://www.ytk-group.co.jp](http://www.ytk-group.co.jp)  
[info@ytk-group.co.jp](mailto:info@ytk-group.co.jp)