

DC Brush Motor

Scooter-SC71 Series (2Poles)
差速器馬達 / Transaxle Motor



● 圖紙 / Drawing

- 註: 1. 雙圓鍵: 2-5*5*30(左右各一個)
2. C型扣環: 軸用 $\phi 17$ (左右各一個)
3. 軟式橡膠襯套(左右各一個)

MODEL:
RATIO : 1:20.33
MOTOR : DC24V 3.0A
OUTPUT: 300W
SPEED : 4000 \pm 150rpm
BRAKE : DC24V 0.45A 30kgfcm
NOISE : 65dba(max)

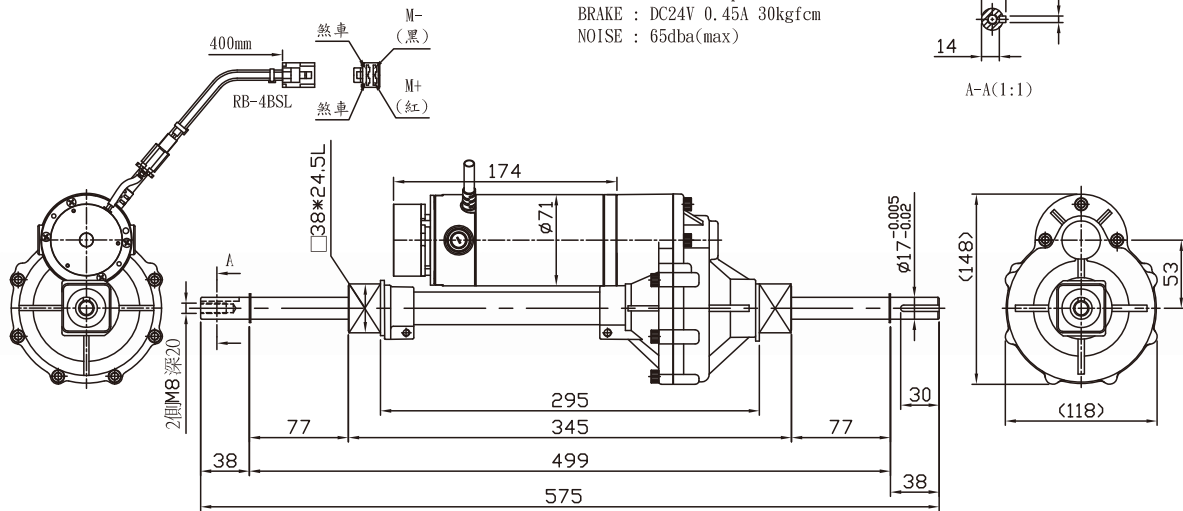

● 曲線圖 / Curve

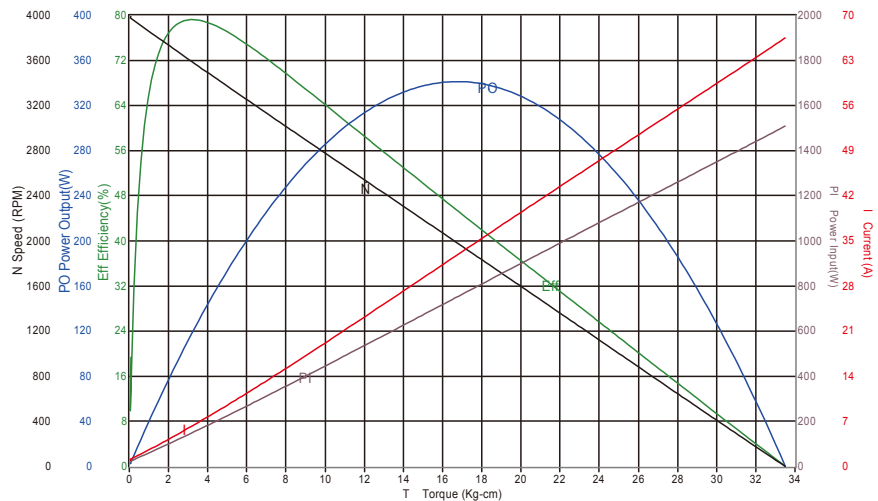

● 規格 / Spec.

馬達機種 / Motor Type	Model SC71 系列 (2 極) / SC71 Series (2Poles)
外徑 Diameter	$\phi 71$
IP 等級 IP Degree	IP44
電壓 Voltage	12V / 24V / 36V / 48V
輸出功率 Output Watt	100W ~ 300W
減速比 Gearbox Ratio	20.33:1
轉速 RPM	2500 - 5700
額定載重 Rated Loading	130KG