

BLDC2832

Brushless Dc Motor

Application : Roomba

用途：吸塵機器人

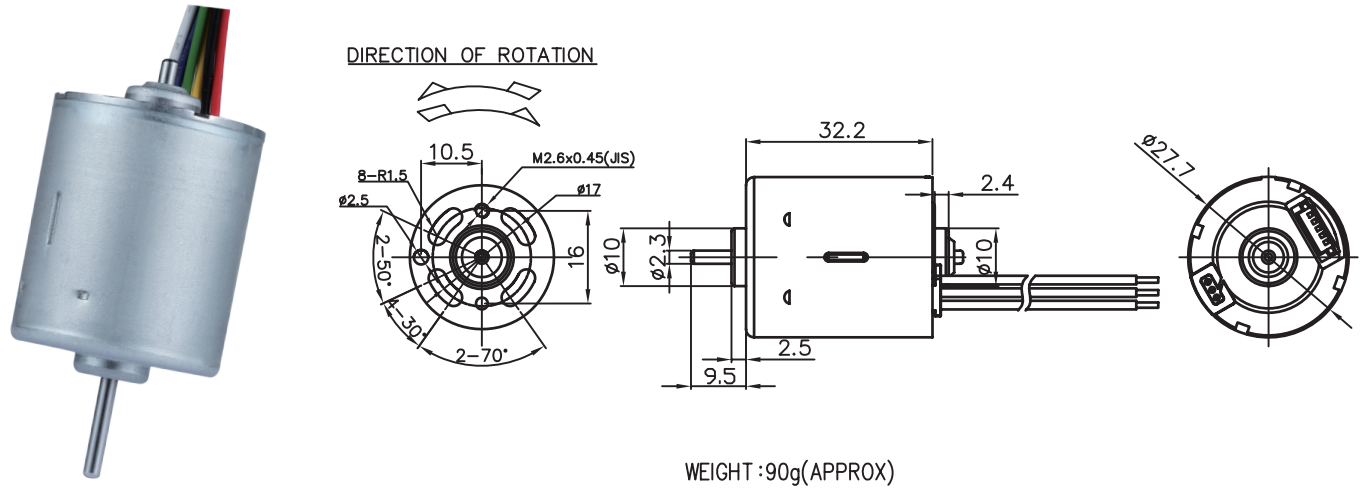

MODEL	VOLTAGE		NO LOAD		AT MAXIMUM EFFICIENCY					STALL			
	OPERATING RANGE	NOMINAL	SPEED rpm	CURRENT A	SPEED rpm	CURRENT A	TORQUE g-cm	TORQUE mN-m	OUTPUT W	EFF %	CURRENT A	TORQUE g-cm	TORQUE mN-m
BLDC2832B0W0	-----	12.0V CONSTANT	3500	0.67	2719	0.28	53.11	5.21	1.48	55	0.86	233.20	22.86
BLDC2832B1W2	-----	12.0V CONSTANT	17700	0.17	14144	0.85	46.87	4.60	6.81	73	4.23	281.64	27.61

馬達的出軸長度及性能參數，EMC 對策可依客人要求做調整，詳情可詢問相關業務人員。
Please inquire your sales representative for output, performance and EMC solution.

