

9812/9824

Carbon-brush motors

Application : Sewing Machine

用途：縫紉機

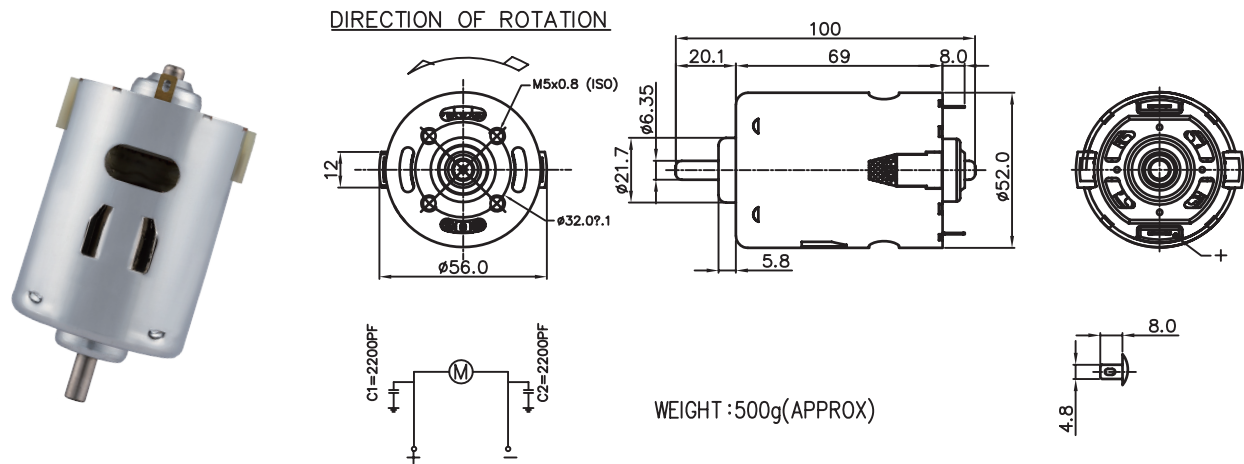

MODEL	VOLTAGE		NO LOAD		AT MAXIMUM EFFICIENCY					STALL			
	OPERATING RANGE	NOMINAL	SPEED	CURRENT	SPEED	CURRENT	TORQUE	OUTPUT	EFF	CURRENT	TORQUE		
			rpm	A	rpm	A	g-cm	mN-m	W	%	A	g-cm	mN-m
9812-1974	90 - 150	125V CONSTANT	11000	0.20	9300	1.05	999	97.94	96.24	73	7.08	7670	751.96
9824-1639	90 - 150	125V CONSTANT	10200	0.23	8200	1.15	1094	107.25	92.23	65	5.00	5880	576.47

馬達的出軸長度及性能參數，EMC 對策可依客人要求做調整，詳情可詢問相關業務人員。
Please inquire your sales representative for output, performance and EMC solution.

