

Application : Drill & Screwdriver 、 Electric gate

用途：電動工具、電動門

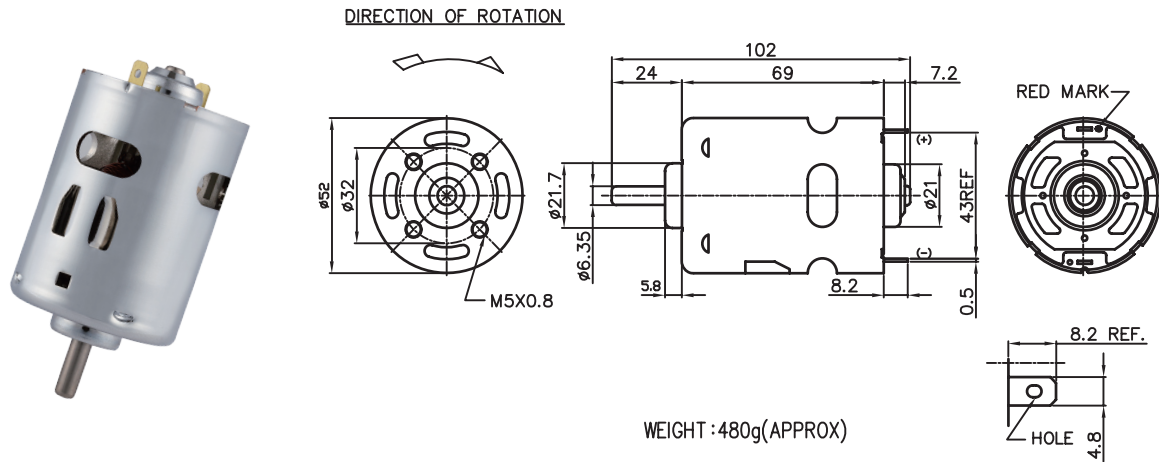

MODEL	VOLTAGE		NO LOAD		AT MAXIMUM EFFICIENCY					STALL			
	OPERATING RANGE	NOMINAL	SPEED	CURRENT	SPEED	CURRENT	TORQUE	OUTPUT	EFF	CURRENT	TORQUE		
			rpm	A	rpm	A	g-cm	mN-m	W	%	A	g-cm	mN-m
987-4042	12.0 - 36.0	24.0V CONSTANT	6000	0.80	5000	2.46	803	78.73	41.23	69.53	15.55	5855	574
987-5521	6.0 - 36.0	12.0V CONSTANT	6000	1.50	4960	4.99	777	76.18	39.58	67.20	27.27	4996	490
987-6023	12.0 - 40.0	40.0V CONSTANT	20000	2.40	17513	10.43	1760	172.55	316.54	77.07	67.77	13590	1332
987-7514	6.0 - 26.0	24.0V CONSTANT	20000	3.80	17036	15.18	1558	152.75	272.58	76.87	101.63	12754	1250

馬達的出軸長度及性能參數，EMC 對策可依客人要求做調整，詳情可詢問相關業務人員。
Please inquire your sales representative for output, performance and EMC solution.

