

Application : Drill & Screwdriver 、 Copy Machine 、 Massager

用途：電動工具、影印機、電動按摩器

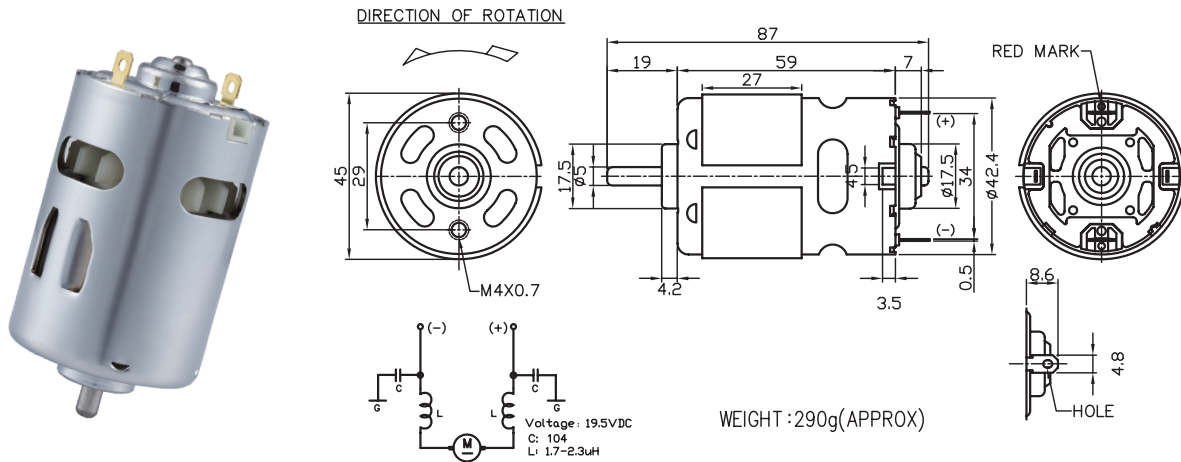

MODEL	VOLTAGE		NO LOAD		AT MAXIMUM EFFICIENCY					STALL			
	OPERATING RANGE	NOMINAL	SPEED rpm	CURRENT A	SPEED rpm	CURRENT A	TORQUE g-cm	OUTPUT W	EFF %	CURRENT A	TORQUE g-cm	TORQUE mN-m	
755-3090	18.0 - 36.0	24.0V CONSTANT	5200	0.30	4715	0.94	363	35.59	17.58	78.63	8.20	3530	346.08
755-8016SF	9.6 - 20.0	18.0V CONSTANT	23000	3.50	19569	20.21	1346	131.96	270.50	75.30	104.77	8276	811.37
755-8513SF	6.0 - 18.0	12.0V CONSTANT	18000	3.50	15748	16.68	876	85.88	141.67	75.00	142.48	8396	823.14
755-7018SF-CE-IE	15.0 - 24.0	19.5V CONSTANT	22500	3.50	19011	14.81	1107	108.53	216.13	77.00	86.93	7950	779.41

馬達的出軸長度及性能參數，EMC 對策可依客人要求做調整，詳情可詢問相關業務人員。  
Please inquire your sales representative for output, performance and EMC solution.

