

# K3SFN

## Carbon-brush motors

Application : Massager 、Drill & Screwdriver

用途：電動按摩器、電動工具

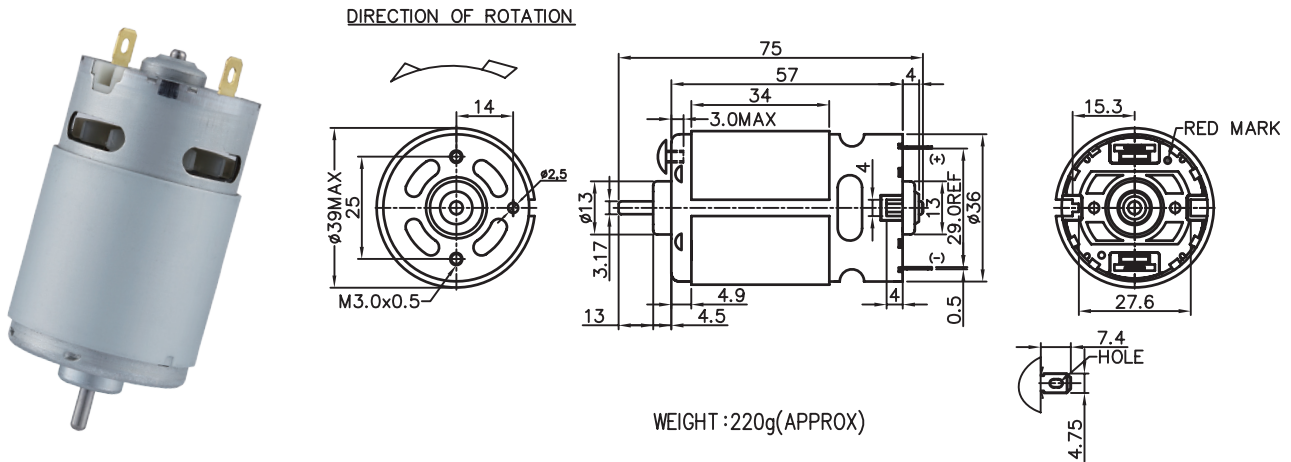

MODEL	VOLTAGE		NO LOAD		AT MAXIMUM EFFICIENCY					STALL			
	OPERATING RANGE	NOMINAL	SPEED	CURRENT	SPEED	CURRENT	TORQUE	OUTPUT	EFF	CURRENT	TORQUE		
			rpm	A	rpm	A	g-cm	mN-m	W	%	A	g-cm	mN-m
KV3SFN-8022F	6.0 - 12.0	12.0V CONSTANT	21000	1.8	18248	14.46	704	69.02	131.93	79	111.93	6510	638.24
KC3SFN-8023F	6.0 - 12.0	10.8V CONSTANT	20000	2.2	15798	12.31	616	60.39	99.93	77	82.63	4852	449.22
KC3SFN-8515F	6.0 - 9.6	7.2V CONSTANT	20000	3.5	17668	13.18	421	41.27	76.39	80	97.44	3594	527.45
KC3SFN-8519F	6.0 - 9.6	9.6V CONSTANT	20000	2.8	18018	12.72	528	51.76	97.70	80	104.36	4897	480.10

馬達的出軸長度及性能參數，EMC 對策可依客人要求做調整，詳情可詢問相關業務人員。  
Please inquire your sales representative for output, performance and EMC solution.

