

Application : Drill & Screwdriver 、 Automotive Water Pump

用途：電動工具、汽車噴水泵

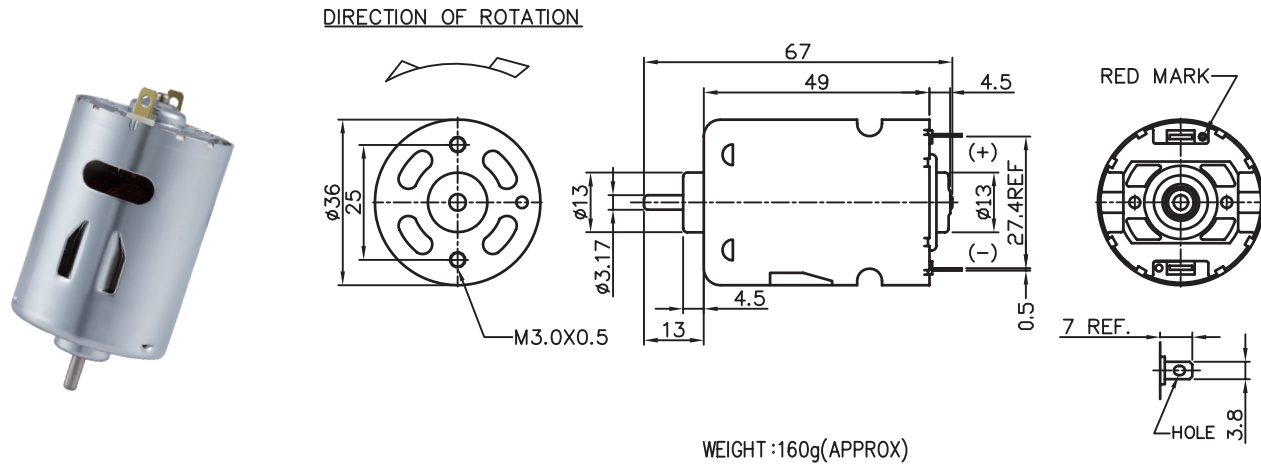

MODEL	VOLTAGE		NO LOAD		AT MAXIMUM EFFICIENCY					STALL			
	OPERATING RANGE	NOMINAL	SPEED	CURRENT	SPEED	CURRENT	TORQUE	OUTPUT	EFF	CURRENT	TORQUE		
			rpm	A	rpm	A	g-cm	mN-m	W	%	A	g-cm	mN-m
HD3SFN-6035	6.0 - 12.0	12.0V CONSTANT	20500	1.00	17200	8.25	380	37.25	67.17	68	56.32	2920	286.27
HD3SFN-6040	6.0 - 12.0	6.0V CONSTANT	8600	1.00	7300	5.90	326	31.96	24.82	70	38.69	2375	232.84
HS3SFN-7523	3.6 - 6.0	4.8V CONSTANT	14000	1.80	11600	9.10	244	23.92	29.34	68	53.75	1685	165.20
HS3SFN-22240	6.0 - 24.0	12.0V CONSTANT	3100	0.12	2600	0.44	125	12.25	3.34	62	2.29	790	77.45

馬達的出軸長度及性能參數，EMC 對策可依客人要求做調整，詳情可詢問相關業務人員。  
Please inquire your sales representative for output, performance and EMC solution.

