

Application : Vacuum Cleaner 、 Drill & Screwdriver 、 Pump

用途：吸塵器、電動工具、泵浦

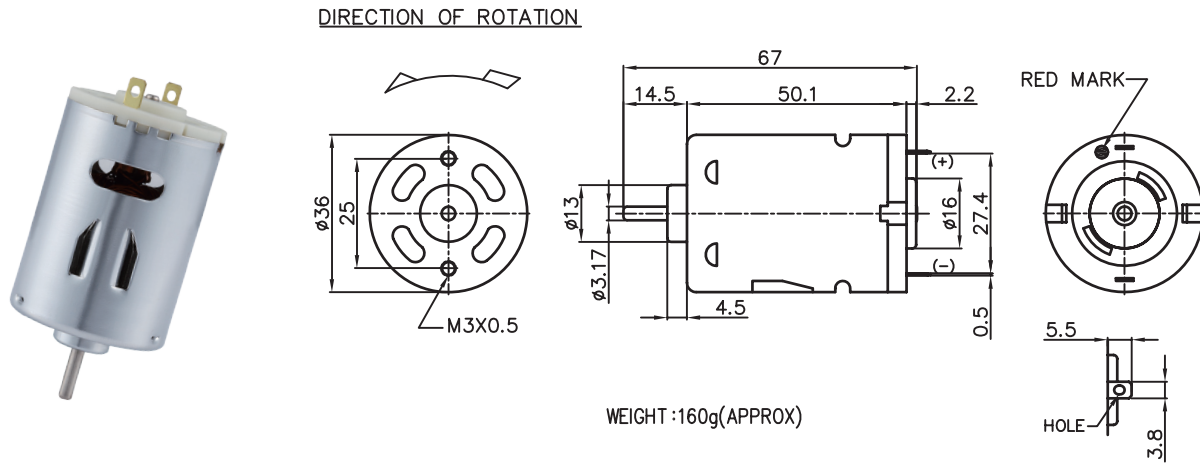

MODEL	VOLTAGE		NO LOAD		AT MAXIMUM EFFICIENCY					STALL			
	OPERATING RANGE	NOMINAL	SPEED rpm	CURRENT A	SPEED rpm	CURRENT A	TORQUE g-cm	TORQUE mN-m	OUTPUT W	EFF %	CURRENT A	TORQUE g-cm	TORQUE mN-m
HS5N-4525	6.0 - 12.0	6.0V CONSTANT	8700	1.00	6800	3.30	190	18.63	13.25	66	12.10	880	86.27
HS5N-16200	12.0 - 24.0	24.0V CONSTANT	4100	0.60	3500	0.24	96	9.41	3.49	66	1.41	738	72.35
HP5N-20120	12.0 - 24.0	12.0V CONSTANT	3100	0.12	2300	0.47	129	12.65	3.17	56	1.79	612	60.00
HP5N-20130	12.0 - 24.0	24.0V CONSTANT	5600	0.12	4600	0.51	161	15.78	7.71	66	2.90	1148	112.55

馬達的出軸長度及性能參數，EMC 對策可依客人要求做調整，詳情可詢問相關業務人員。
Please inquire your sales representative for output, performance and EMC solution.

